

# casemagiQ<sup>®</sup>

Patent Pending

## CM100

The World's First  
Universal Case Forming EOAT

Case Forming.  
Plug & Play.



reddot winner 2024



Any Robot | Any Case

**IMPACT**  
ROBOTICS



## casemagiQ CM100

casemagiQ is a revolutionary End of Arm Tooling solution, designed specifically for automating the case forming process, commonly known as carton erection or case forming.

This innovative product transforms flat cartons into fully formed boxes, addressing a critical step in packaging and distribution.

Unlike traditional end of arm tooling, which requires custom design and assembly by specialized integrators, casemagiQ offers an out-of-the-box, plug-and-play solution, avoiding need for customization.

### Value Proposition

casemagiQ democratizes robotic case forming by offering a streamlined, efficient solution that eliminates the complexity and extended project timelines associated with custom-designed tooling.

Traditionally, designing and assembling case forming tooling involved coordinating with mechanical and electrical designers, sourcing numerous components, and managing the intangible costs of procurement. This process could take anywhere from 4 to 8 weeks to complete.

casemagiQ's plug-and-play design significantly reduces setup time, making it an attractive option for businesses looking to enhance their packaging operations without the traditional hassles.

## Key Features

One of casemagiQ's standout features is its innovative design, which includes just one inlet for pneumatic air that internally distributes and controls both the pneumatic cylinder and generate vacuum for suction.

This compact product weighs only 1.3 kg, making it the lightest end of arm tooling available for carton erection.

It is equipped with 5 vacuum cups to securely hold the carton, with one adjustable cup to accommodate larger sizes.

Additionally, casemagiQ features a snap-fit compartment for easy maintenance and an onboard controller for seamless integration with robot controllers, eliminating the need for specialized PLC programming.

## Advantages

casemagiQ's design offers several advantages over traditional end of arm tooling.

Its lightweight, compact form factor and internal air distribution system reduce the complexity and clutter of multiple tubes and components. This not only streamlines the installation process but also facilitates easier maintenance and adaptability to different carton sizes.

Furthermore, the simplified communication with robot controllers through the onboard controller enhances the product's usability, making it an ideal choice for companies seeking to automate their packaging processes with minimal technical overhead.

## Applications

The versatility and ease of use of casemagiQ make it suitable for a wide range of applications in industries that require efficient, reliable case erection.

From manufacturing and distribution centers to retail and e-commerce fulfillment operations, casemagiQ can significantly enhance productivity and operational efficiency.

Its ability to handle various carton sizes and shapes with minimal setup changes allows businesses to quickly adapt to changing packaging needs, thereby improving throughput and reducing downtime in their packaging lines.

magic with cases.

# casemagiQ<sup>®</sup>

Patent Pending

Compressed Air Inlet

Extension Arm

Extension Arm Lock

Maintenance Hatch

Robot Coupler

I/O Connector & Status Indicator

Case Forming Flap & Safety Cover

Folding Speed Control

Laser Aligner

Vacuum Cups

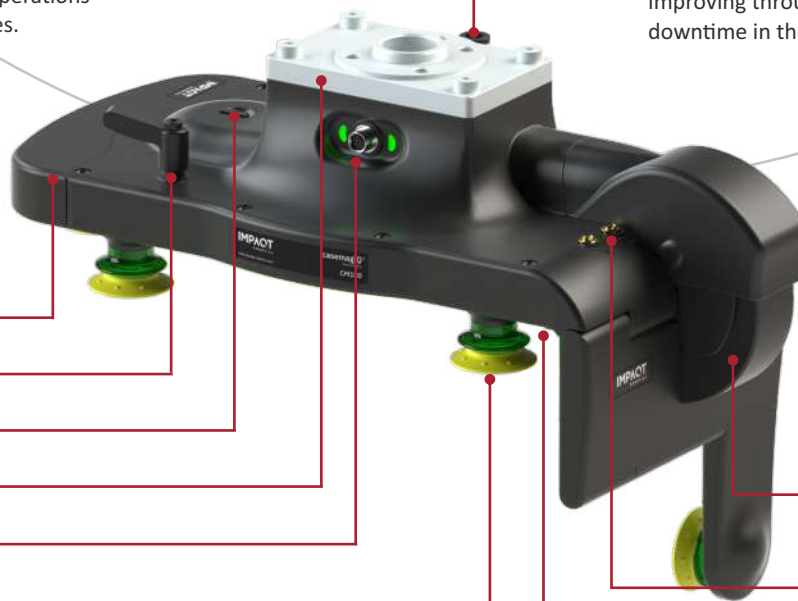

Install in just 10 minutes

## Plug & Play Approach

Plug & Play design ensures immediate integration and operation with existing robotic systems, dramatically reducing setup time and allowing for instant productivity gains.

## Optimized Mechanical Form Factor

The compact size, light weight & sleek design of casemagiQ allows it to be seamlessly installed on the robotic arm. The extendable arm & flap folding speed controller allows for quick changeover for different sizes.

## Rugged Design

casemagiQ's sturdy design allows it to withstand the rigors of industrial environments, ensuring durability and reliability even in the most demanding applications

## Smart Robot Installation

The single tube air inlet and availability of vacuum & controlling the pneumatic cylinder enables smarter & quicker robot installation.

## Benefits - Integrator

- Plug & Play design enables reduced design complexity.
- Faster project completion saving 4-8 weeks.
- No dependency on skilled design & engineering resources.
- Simplified procurement eliminates coordinating from multiple vendors.
- Reduce installation time to just a few minutes.
- Decrease turnaround of projects - more projects in the same time.
- Aesthetic implementation of the robotic cell.

## Benefits - End User

- Aesthetic robotic cell.
- Single EOAT adaptable for multiple carton sizes.
- Zero maintenance.
- Minimize spares requirement.
- Quicker deployment of projects.
- Quick redeployment for other applications.

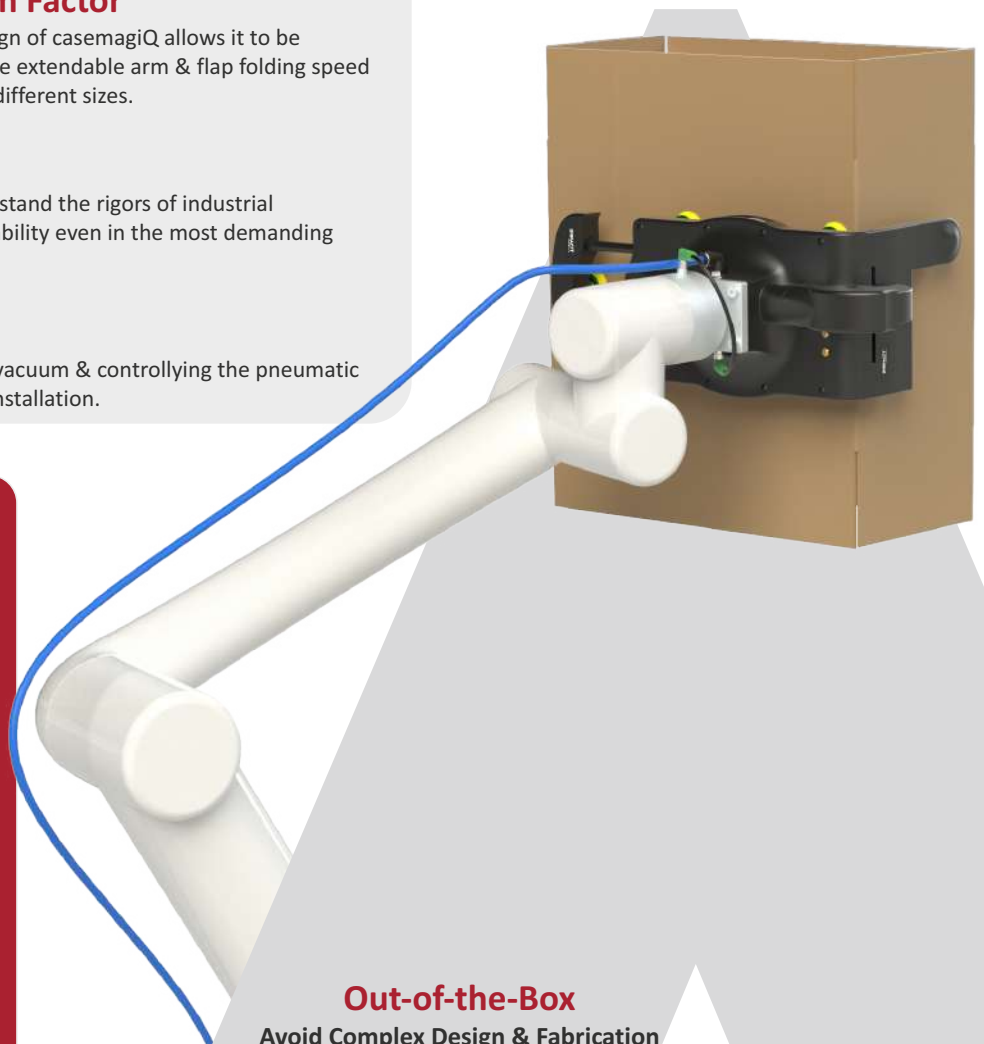

## Out-of-the-Box

Avoid Complex Design & Fabrication

## Laser Aligner

Allows quick alignment for new cartons

## Extendable

Suitable for varying carton sizes

## Quick Install

Accelerate Robot Deployment

## Light

Maximize Robot Payload

## IP54

Use in Industrial Environment



## Specifications

CM100	
Part Number	6 105 1001
<b>General</b>	
Maximum Case Dimension*	500 x 400 x 400 mm
Minimum Case Dimension	240 x 140 x 165 mm
Max. load	3 Kg
Operating medium	Compressed air
Weight	1.35 Kg / 2.9 lbs
Product Dimensions	464 x 176 x 94 mm
<b>Pneumatics</b>	
Maximum vacuum pressure	-850 mbar / -12.5 psi
Maximum operating pressure	6 bar / 87 psi
<b>Communication</b>	
All robots / controllers	Modbus RTU (RS-485)

\*Maximum case dimension is dependent on case quality

## Product Lineup

**cobotizur®**  
the collaborative palletizer  
The CoBot Palletizing Platform

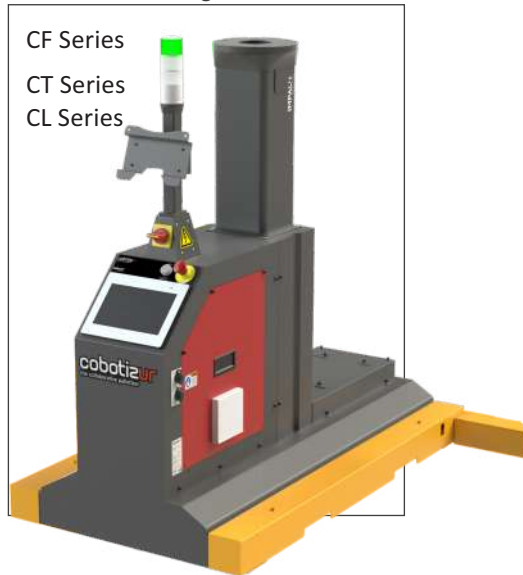

**Qik-kit®**  
Cable Management System

**Qik-mount®**  
CoBot Peripherals

**pneumagiQ®**  
Patented

Universal Pneumatic EOAT Interface



**pneuvaQ®**  
Patent Pending

Integrated Pneumatic + Vacuum Interface



**casemagiQ®**  
Patent Pending

Universal Case Forming EOAT



## Robot Compatibility

**ABB**

**DOOSAN**



**FANUC**

**JAKA**



**KUKA**

**OMRON**

**TM  
ROBOT**



**YASKAWA**

and more...



reddot winner 2024



reddot winner 2023  
innovative product



reddot winner 2023



**IMPACT**  
ROBOTICS

Impaqt Robotics Private Limited  
267 Kilpauk Garden Road, Chennai 600 010, India  
+91-44-4294-9060  
sales@impaqt-robotics.com  
www.impaqt-robotics.com

6 900 1101